

### Sendix absolut, Multiturn Type 5868 (Shaft) / 5888 (Hollow shaft), Profibus-DP

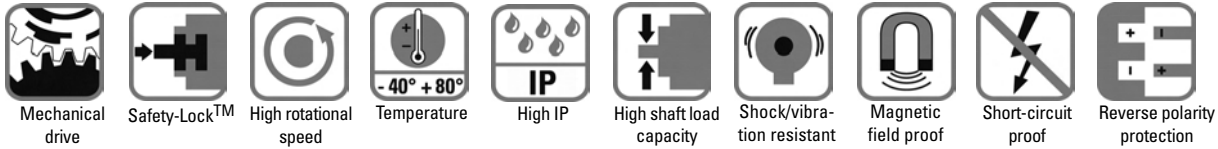

#### Reliable

- **Increased ability to withstand vibration and installation errors. Eliminates machine downtime and repairs.**  
Sturdy "Safety-Lock™ Design" bearing structure
- **Fewer components and connection points increase the operational reliability**  
Kübler OptoASIC technology with highest integration density (Chip-on-Board)
- **Remains sealed, even in the roughest environments, ensures highest safety against field breakdowns**  
Resistant die cast housing and protection up to IP 67
- **Can be used in a wide temperature range without additional expense**  
Wide temperature range
- **Immediate recognition of error-free bus operation**

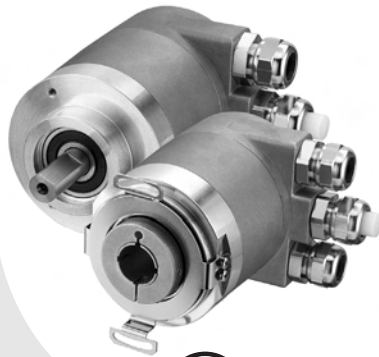

Sendix absolut

#### Fast

- **Fast data availability while reducing the load on the bus and the control**  
Intelligent functions like the transmission of speed, acceleration or exiting a working area
- **Fast, simple and error-free connection**

#### Versatile

- **Up-to-the minute field bus performance in the application**  
Profibus-DPV0 with the current encoder profile supports Class 1 and Class 2  
Enhanced programming possibilities
- **Connection options**  
Bus cover with M12 connector or cable connection
- **Fast start-up** with pre-defined GSD file  
A variety of scaling options for the most diverse applications  
16 bit singleturn resolution  
12 bit multiturn resolution  
Comprehensive diagnostics, programmable to Class 2
- **Reliable installation in a wide diversity of mounting situations**  
Extensive choice of proven mounting options
- also available in **seawater resistant** version, certified acc. to salt-spray test IEC 68-2-11 => 672 hours.

#### Mechanical characteristics:

Max. speed without shaft seal (IP 65) up to 70 °C:	9 000 min <sup>-1</sup> , continuous 7 000 min <sup>-1</sup>
Max. speed without shaft seal (IP 65) up to Tmax:	7 000 min <sup>-1</sup> , continuous 4 000 min <sup>-1</sup>
Max. speed with shaft seal (IP 67) up to 70 °C:	8 000 min <sup>-1</sup> , continuous 6 000 min <sup>-1</sup>
Max. speed with shaft seal (IP 67) up to Tmax:	6 000 min <sup>-1</sup> , continuous 3 000 min <sup>-1</sup>
Starting torque without shaft seal (IP65):	< 0.01 Nm
Starting torque with shaft seal (IP67):	< 0.03 Nm
Moment of inertia:	Shaft version: 4.0 x10 <sup>-6</sup> kgm <sup>2</sup> Hollow shaft version: 7.5 x10 <sup>-6</sup> kgm <sup>2</sup>
Radial load capacity of shaft:	80 N
Axial load capacity of shaft:	40 N
Weight:	approx. 0.57 kg with bus terminal cover approx. 0.52 kg with fixed connection
Protection acc. to EN 60 529:	housing: IP 67, shaft: IP 65, opt. IP 67
EX approval for hazardous areas:	optional zone 2 and 22
Working temperature:	-40° C ... +80 °C
Materials:	Shaft: stainless steel, Flange: aluminium, Housing: die cast zinc
Shock resistance acc. to DIN-IEC 68-2-27:	>2500 m/s <sup>2</sup> , 6 ms
Vibration resistance acc. to DIN-IEC 68-2-6:	>100 m/s <sup>2</sup> , 55 ... 2000 Hz



- Absolutely safe operation even in strong magnetic fields
- Over 40 years of experience in the field of precision mechanics
- Special gears with specific toothings

### Sendix absolut, Multiturn Type 5868 (Shaft) / 5888 (Hollow shaft), Profibus-DP

#### General electrical characteristics:

Supply voltage:	10 ... 30 V DC
Current consumption (w/o output load):	24 V DC, max.90 mA
Reverse polarity protection at power supply (U <sub>B</sub> ):	Yes
Conforms to CE requirements acc. to EN 61000-6-2, EN 61000-6-4 and EN 61000-6-3	
UL certified	File 224618
RoHS compliant acc. to EU guideline 2002/95/EG	

#### Interface characteristics Profibus-DP

Singleturn resolution (max, scaleable):	1 ... 65536 (16 bits), default scale value is set to 8192 (13 bits)
Total resolution:	28 Bit (scaleable 1 ... 2 <sup>28</sup> steps)
Number of Revolutions:	4096 (12 bits), (scaleable 1 ... 4096)
Code:	Binary
<b>Interface:</b>	Specification according to Profibus-DP 2.0 Standard (DIN 19245 Part 3) RS-485 driver galvanically isolated.

#### Profibus Encoder-Profile V1.1

The PROFIBUS-DP device profile describes the functionality of the communication and the user-specific component within the PROFIBUS field bus system. For encoders, the encoder profile is definitive. Here the individual objects are defined independent of the manufacturer. Furthermore, the profiles offer space for additional manufacturer-specific functions; this means that PROFIBUS-compliant device systems can be used now with the guarantee that they are ready for the future too.

#### The following parameters can be programmed:

- Direction of rotation
- Scaling
- Number of steps per revolution
- Number of revolutions
- Total resolution over Singleturn/Multiturn
- Preset value
- Diagnostics mode

#### Terminal assignment with terminal box:

Signal :	BUS IN				BUS OUT				
	B	A	0	V	+V	0V	+V	B	A
Pin :	1	2	3	4	5	6	7	8	

Shield must be connected to the cable gland (with the contact surface as large as possible).

#### Terminal assignment M12 connector version:

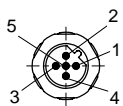

Bus in:

Signal :	–	BUS-A	–	BUS-B	Shield
Pin:	1	2	3	4	5

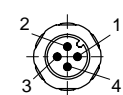

Power supply:

Signal :	U <sub>B</sub>	–	0	V	–
Pin:	1	2	3	4	

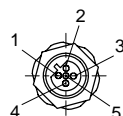

Bus out:

Signal :	BUS_VDC <sup>1)</sup>	BUS-A	BUS_GND <sup>1)</sup>	BUS-B	Shield
Pin:	1	2	3	4	5

<sup>1)</sup> for powering an external Profibus-DP terminating resistor

#### SET control button (zero or defined value, option)

Protected against accidental activation, can only be pushed in with the tip of a ball pen or similar.

#### Diagnostic LED (yellow)

LED on with:

optical sensor path faulty (code error, LED error), low voltage and over-temperature

Protocol:	Profibus Encoder Profile V1.1 Class 1 and Class 2 with manufacturer-specific enhancements
Baud rate:	12 Mbits/s
Node address:	1 ... 127 (set by rotary switches / software configurable)
Termination switchable:	Set by DIP switches

#### The following parameters can be configured

- Position 16/32 Bit
- Speed UPM or Unit/s (16/32) Bit

#### The following functionality is integrated:

- Galvanic isolation of the bus stage with DC/DC converter
- Line driver acc. to RS 485 max. 12 MB
- Address programmable via DIP switches
- Diagnostics LED
- Full Class 1 and Class 2 functionality

### Sendix absolut, Multiturn Type 5868 (Shaft) / 5888 (Hollow shaft), Profibus-DP

#### Dimensions shaft version

##### With removable bus terminal cover

ø 58 mm, Synchro flange

Flange type 2 and 4 (Drawing with cable version)

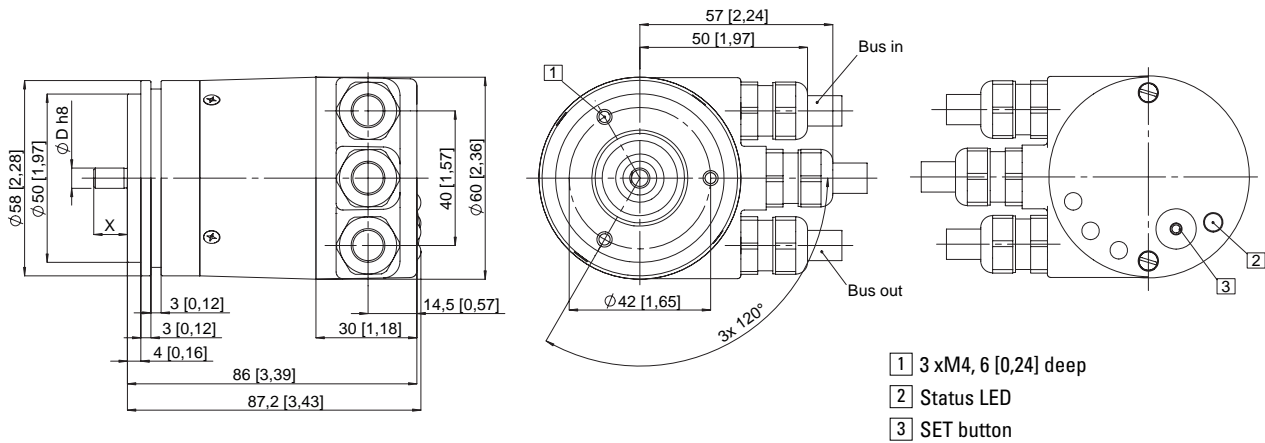

ø 58 mm, Clamping flange

Flange type 1 and 3 (Drawing with 2 x M12 connector)

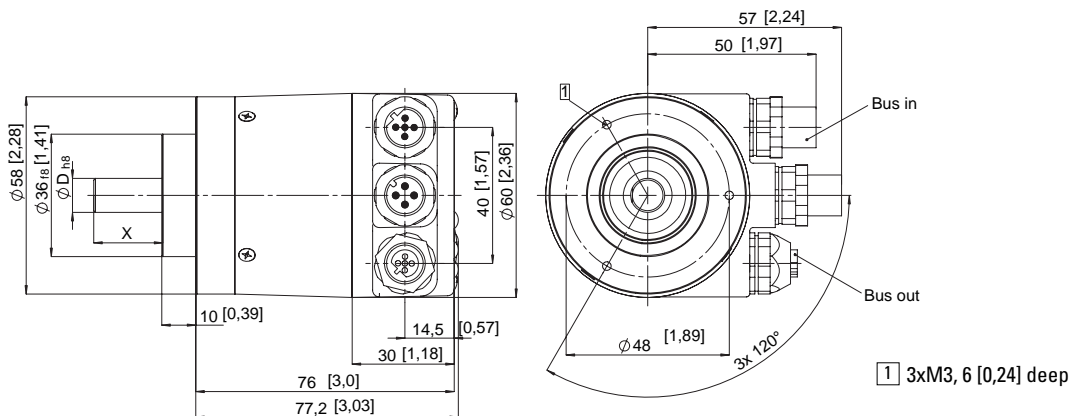

63.5 mm □, Square flange

Flange type 5 and 7 (Drawing with cable version)

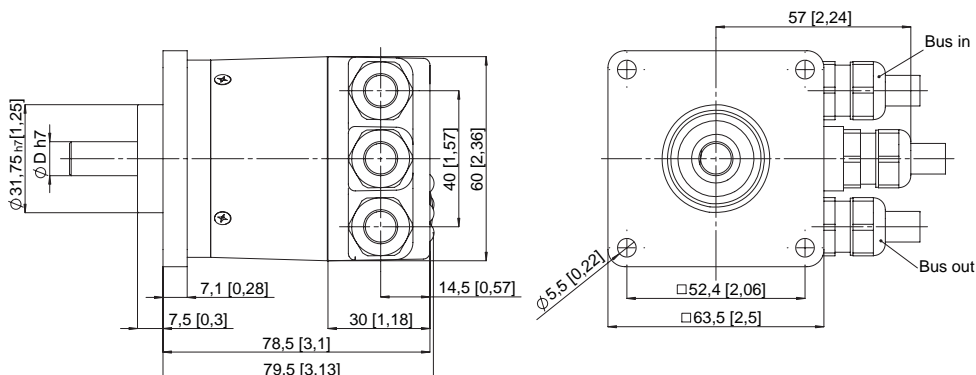

### Sendix absolut, Multiturn Type 5868 (Shaft) / 5888 (Hollow shaft), Profibus-DP

Order code shaft version:

8 . 5 8 6 8 . X X X X . X X 1 X 10 by 10

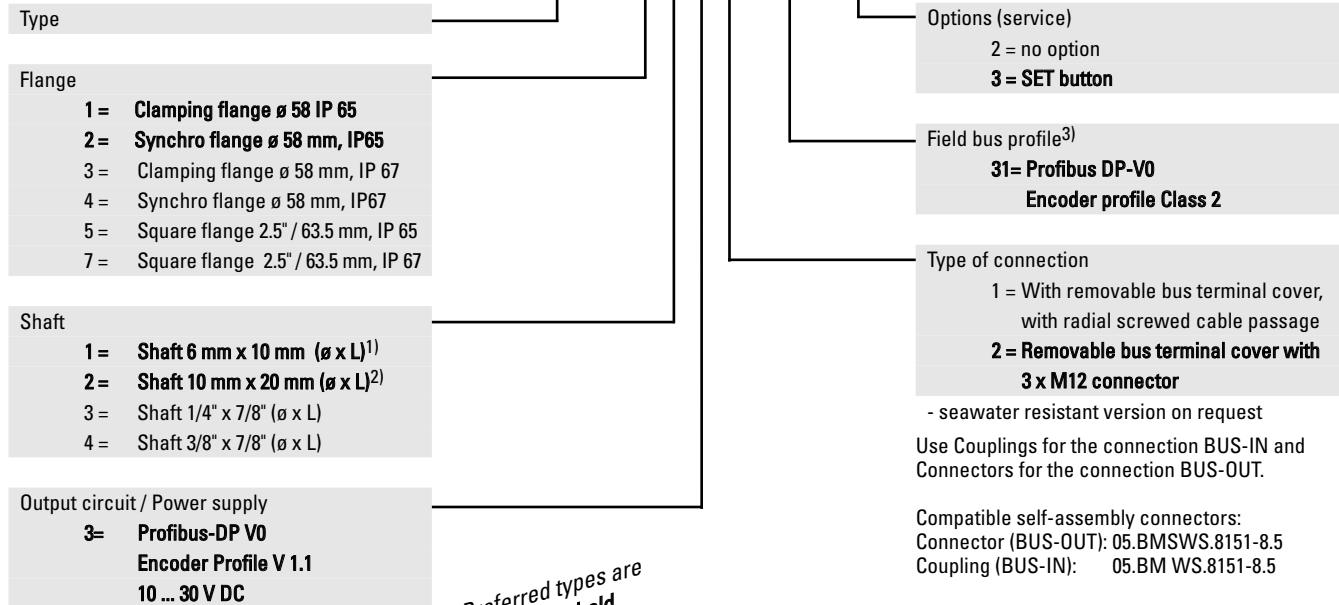

<sup>1)</sup> Preferred type with flange type 2  
<sup>2)</sup> Preferred type with flange type 1

*Preferred types are indicated in bold*

- seawater resistant version on request  
 Use Couplings for the connection BUS-IN and Connectors for the connection BUS-OUT.

Compatible self-assembly connectors:  
 Connector (BUS-OUT): 05.BMSWS.8151-8.5  
 Coupling (BUS-IN): 05.BM.WS.8151-8.5

See also Connection Technology section

**Accessories:**

- Cables and connectors, also pre-assembled, can be found in Connection Technology section
- Mounting attachments and couplings can be found in Accessories section

### Sendix absolut, Multiturn Type 5868 (Shaft) / 5888 (Hollow shaft), Profibus-DP

Dimensions hollow shaft version:

With removable bus terminal cover:

ø 58 mm, Flange with long torque stop

Flange type 1 and 2 (Drawing with 2x M12 connector)

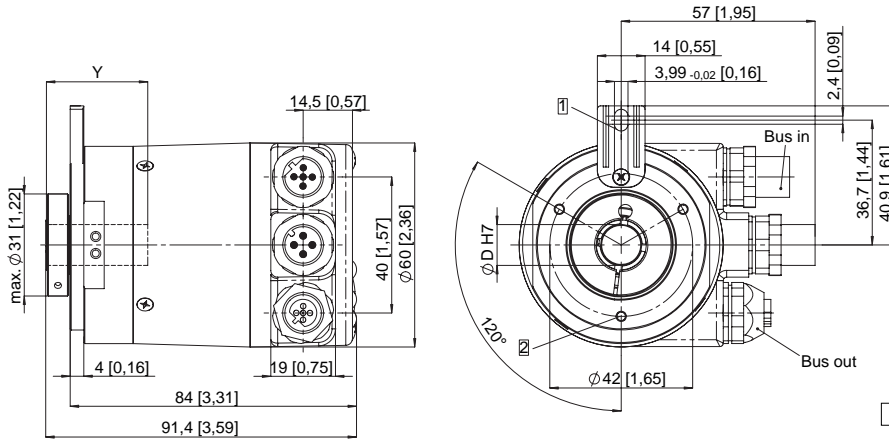

- 1 Torque stop slot,  
Recommendation: cyl. pin. acc. DIN 7 Ø4
- 2 3xM3, 5.5 [0.21]deep

ø 58 mm, Flange with stator coupling

Flange type 5 and 6, pitch circle ø 63 mm (Drawing with cable versions)

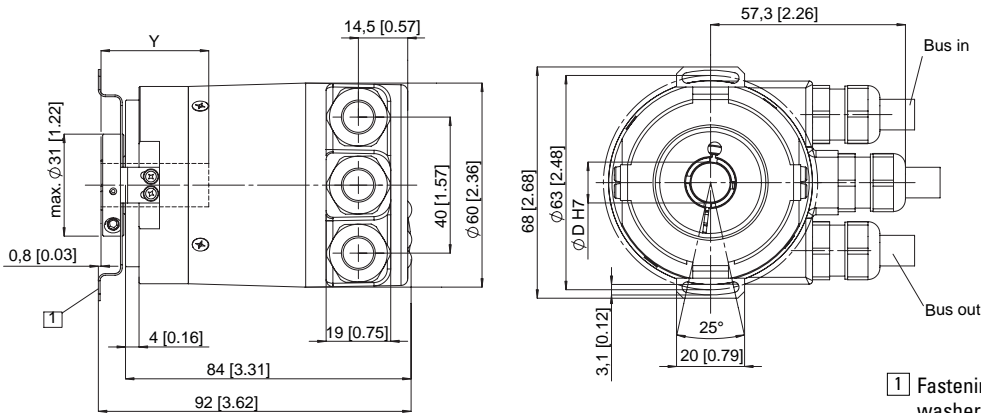

- 1 Fastening screw DIN 912 M3 x 8,  
washer included

ø 58 mm, Flange with stator coupling

Flange type 3 and 4, pitch circle ø 65 mm (Drawing with 2x M12 connector)

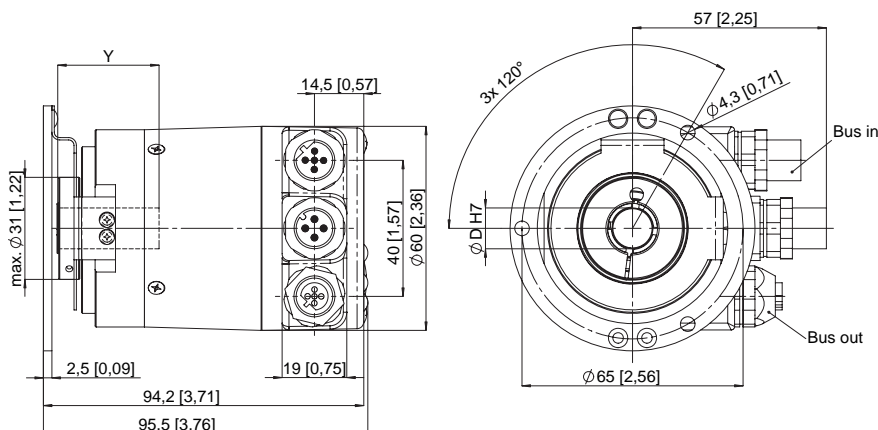

Y: Depth for blind  
hollow shaft: 30 mm

### Sendix absolut, Multiturn Type 5868 (Shaft) / 5888 (Hollow shaft), Profibus-DP

Order code hollow shaft version:

8 . 5 8 8 8 . X X X X . X X 1 X



Type	
Flange	<ul style="list-style-type: none"> <li>1 = Flange with torque stop IP 65</li> <li>2 = Flange with torque stop IP 67</li> <li>3 = Flange with stator coupling pitch circle ø 65, IP 65</li> <li>4 = Flange with stator coupling pitch circle ø 65, IP 67</li> <li><b>5 = Flange with stator coupling pitch circle ø 63, IP 65</b></li> <li>6 = Flange with stator coupling pitch circle ø 63, IP 67</li> </ul>
Hollow shaft	<ul style="list-style-type: none"> <li>3 = Blind hollow shaft ø 10 mm</li> <li><b>4 = Blind hollow shaft ø 12 mm</b></li> <li>5 = Blind hollow shaft ø 14 mm</li> <li>6 = Blind hollow shaft ø 15 mm</li> <li>8 = Blind hollow shaft ø 9.52 mm [3/8"]</li> <li>9 = Blind hollow shaft ø 12.7 mm [1/2"]</li> </ul>
Output circuit / Power supply	<ul style="list-style-type: none"> <li><b>3 = Profibus-DP V0</b></li> <li><b>Encoder Profile V 1.1</b></li> <li><b>10 ... 30 V DC</b></li> </ul>

Options (service)  
 2 = no option  
**3 = SET button**

Field bus profile<sup>3)</sup>  
**31 = Profibus DP-V0**  
**Encoder profile Class 2**

Type of connection  
 1 = With removable bus terminal cover, with radial screwed cable passage  
**2 = Removable bus terminal cover with 3 x M12 connector**  
 - seawater resistant version on request

Use Couplings for the connection BUS-IN and Connectors for the connection BUS-OUT.

Compatible self-assembly connectors:  
 Connector (BUS-OUT): 05.BMSWS.8151-8.5  
 Coupling (BUS-IN): 05.BM.WS.8151-8.5

**Accessories:**

- Cables and connectors, also pre-assembled, can be found in Connection Technology section
- Mounting attachments and couplings can be found in Accessories section

*Preferred types are indicated in bold*